



Innovative Composite Manufacturer

COMPOSITE

Manhole Covers

Extension Chambers

Corrugated Grates

Channel Grilles



TEZKOM COMPOSITE

Operating since 2013 in its facilities located in the Eskişehir Organized Industrial Zone—spanning a total area of 25,000 m² with 13,000 m² of indoor space—the company serves its customers as one of the leading organizations in the composite industry.

The company manufactures composite-based products, which are among the most critical materials of the future, using Pultrusion, Open Molding, SMC and BMC techniques, Hand Lay-up, and Pressing technologies. It offers tailored solutions to meet the requirements of the construction, chemical, defense, food, agriculture, maritime, aviation, and automotive sectors.

Its fully equipped 1,500 m² laboratory, which completed its accreditation process in 2017, stands among Turkey's largest R&D investments. Holding TÜRKAK accreditation, the laboratory leads the industry's development by providing comprehensive testing services from raw materials to final products.

Index

Manhole Covers	3
Extension Chambers	7
Corrugated Grates	11
Channel Grilles	17

Manhole Covers

Manhole Covers A15, B125

Hingeless

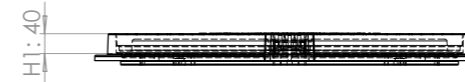
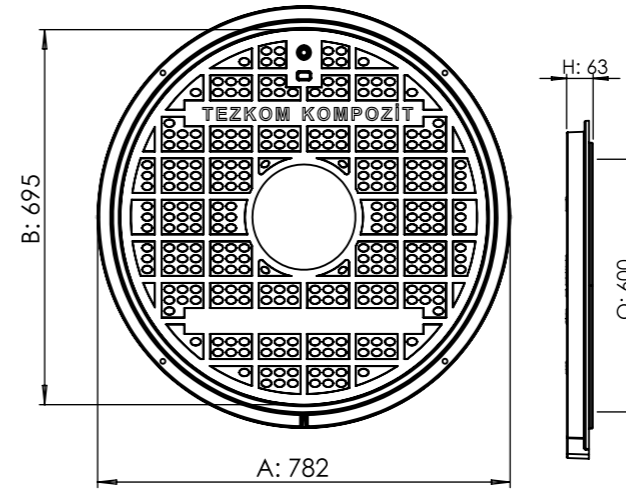

Type	Weight (kg)	Dimensions (mm)				
		A	B	O	H	H1
A15	20	782	695	600	63	40
B125	28,5					

Hinged

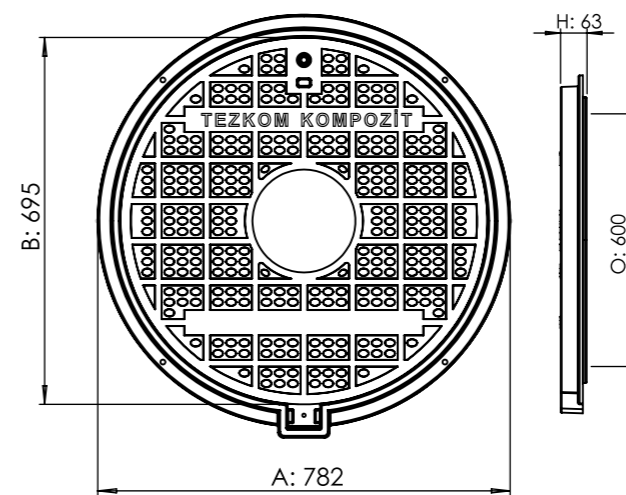

Kapak Açılım : 180°

Type	Weight (kg)	Dimensions (mm)				
		A	B	O	H	H1
A15	20,5	782	695	600	63	40
B125	29					

Manhole Covers C250, D400

Hingeless

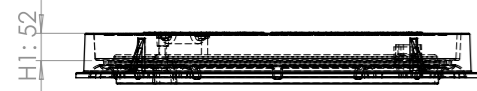
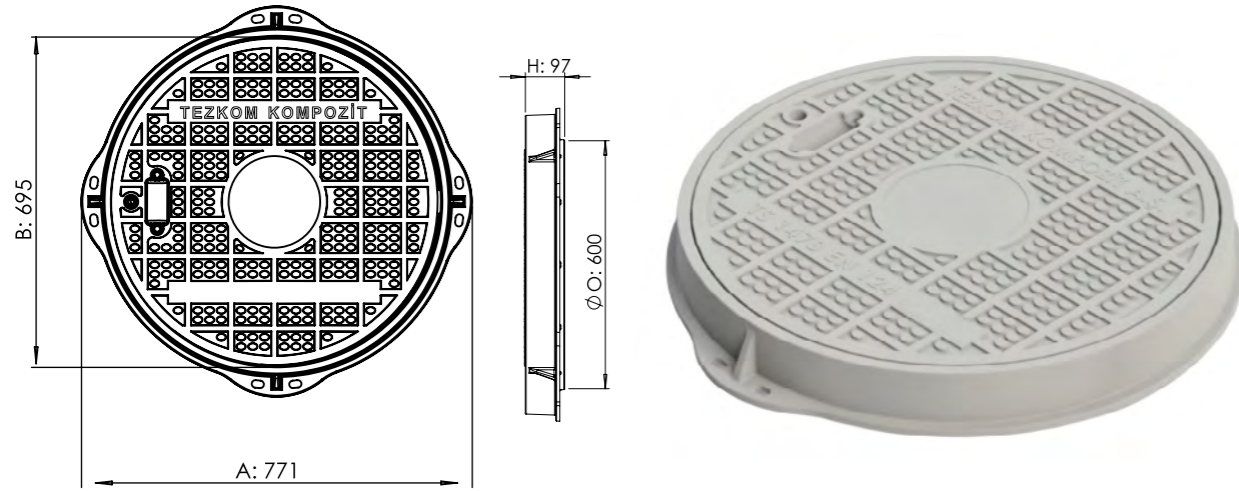

Type	Weight (kg)	Dimensions (mm)				
		A	B	O	H	H1
C250	39,2	771	695	600	97	52
D400	45,2	771	695	600	97	52

Telekom Products

600 x 800 Manhole Cover Set

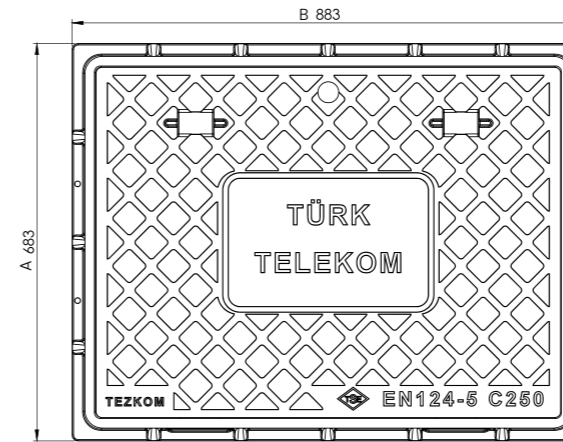

Type	Weight (kg)	Dimensions (mm)			
		A	B	O	H
A15	34,5	683	883	600	74
C250	52	683	883	600	74
D400	65,5	683	883	600	74

Hinged

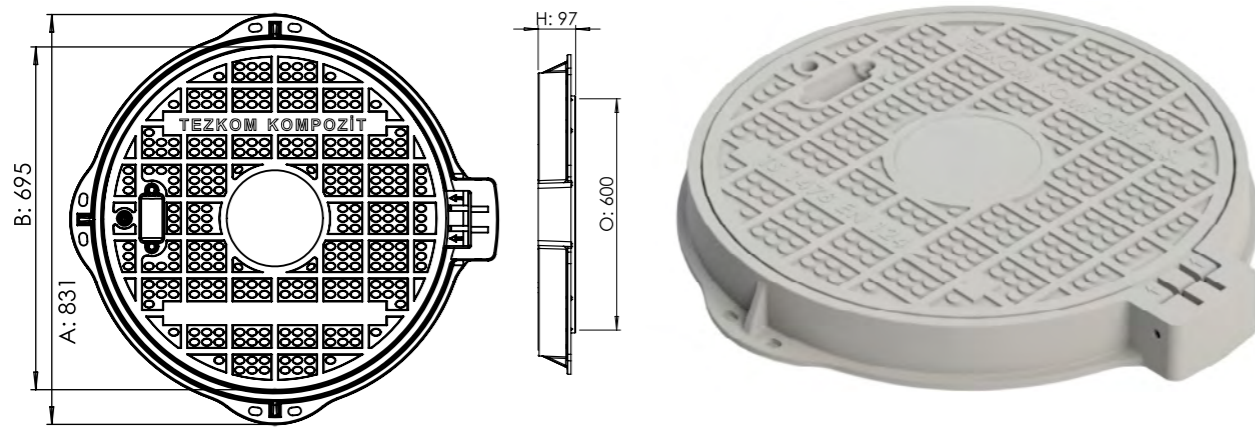

Kapak Açılım : 180°

Type	Weight (kg)	Dimensions (mm)				
		A	B	O	H	H1
C250	40	831	695	600	97	52
D400	46	831	695	600	97	52

Ø643 Manhole Cover Set

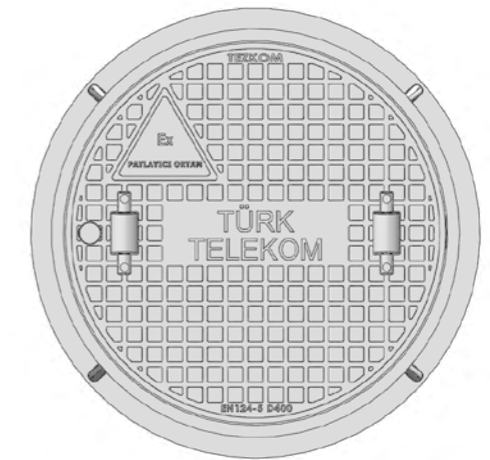
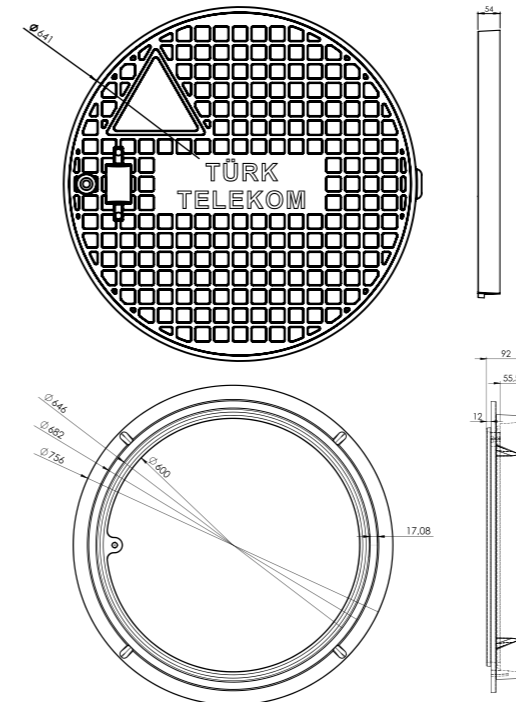

Type	Cover Weight (kg)	Frame Weight (kg)	Total Weight (kg)
D400	31	11,2	42,2

Manhole Chambers

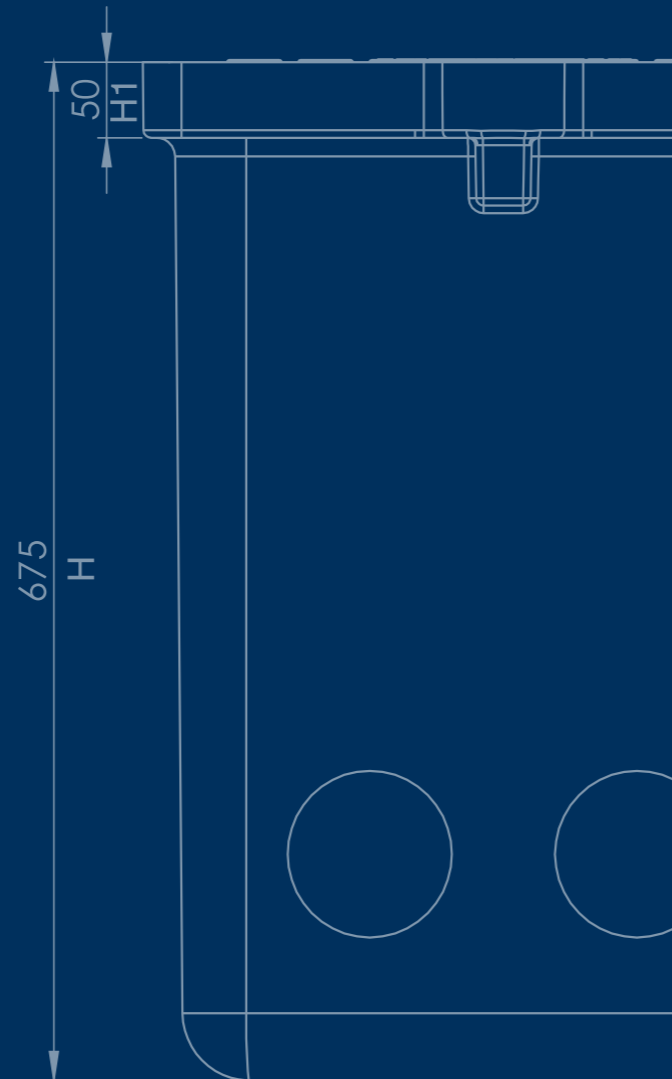
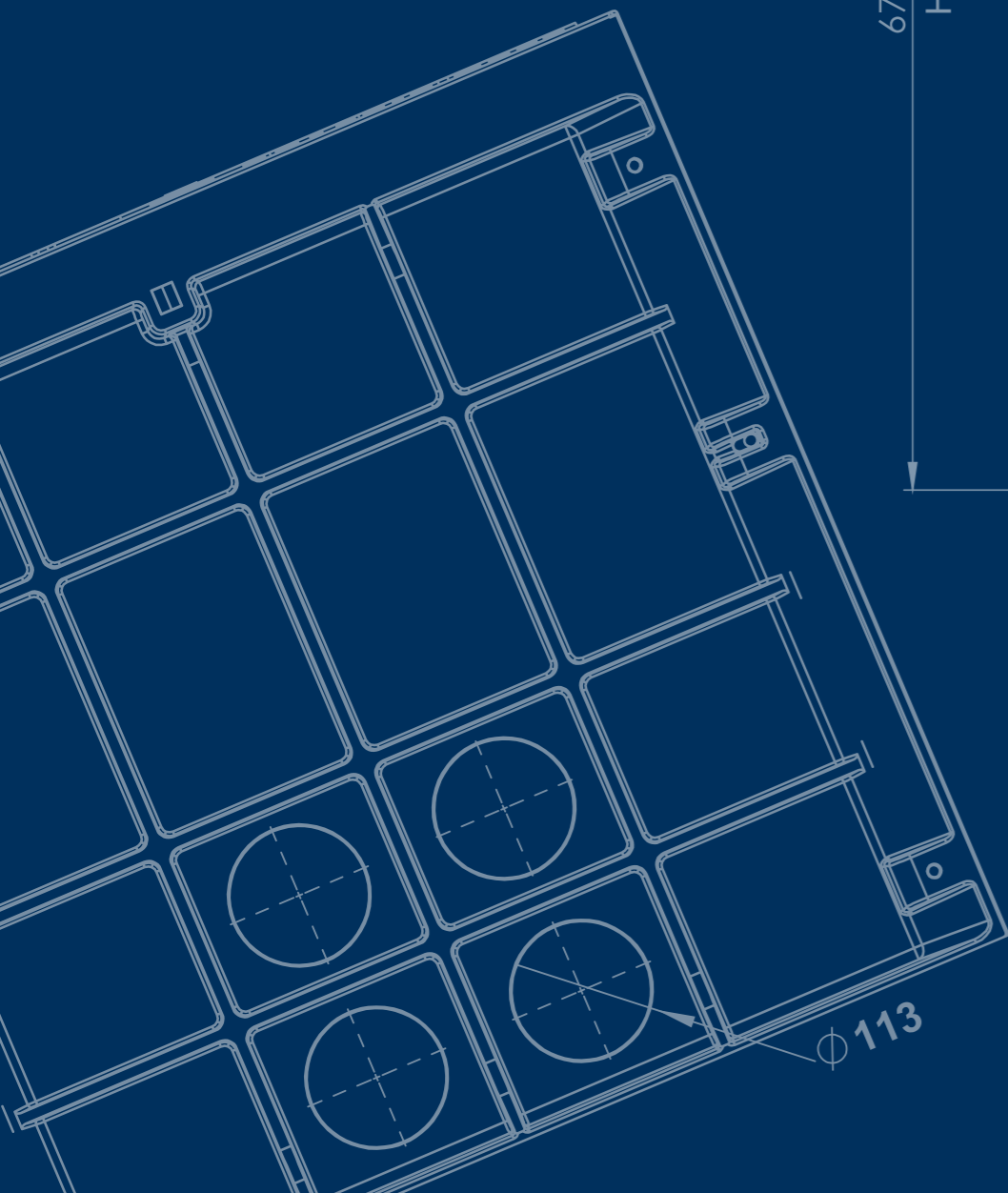

Manhole Chambers

TIP 12, H41 Manhole Chamber

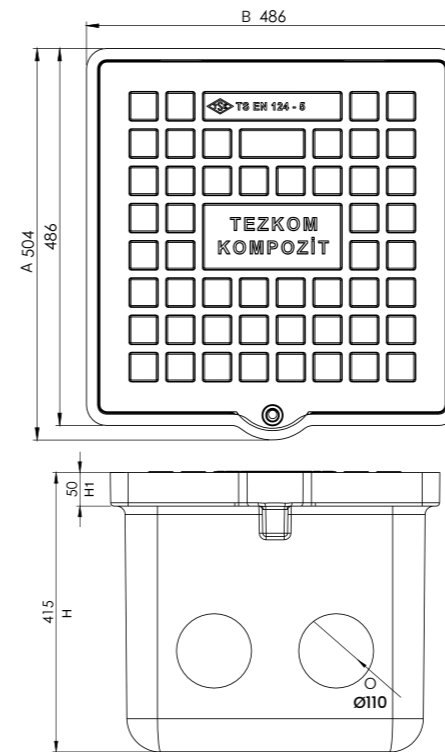

Type	Weight (kg)	Dimensions (mm)				
		A	B	H	H1	O
A15	25,5	504	486	415	50	110
B125	30					
C250	30					
D400	35					

TIP 12, H65 Manhole Chamber

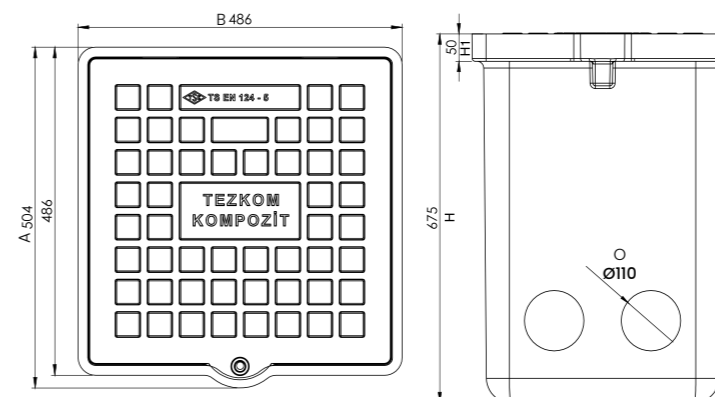

Type	Weight (kg)	Dimensions (mm)				
		A	B	H	H1	O
A15	35,5	504	486	675	50	110
B125	40					
C250	40					
D400	45					

Manhole Chambers

TIP 12, H75 Manhole Chamber

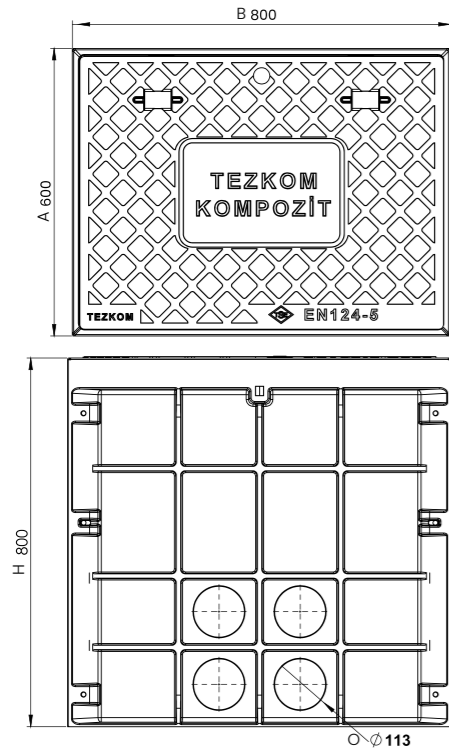

Type	Weight (kg)	Dimensions (mm)			
		A	B	H	O
A15	70	600	800	800	113
C250	87				
D400	101				

TIP 12, H41 Manhole Chamber '38x38 Grid'

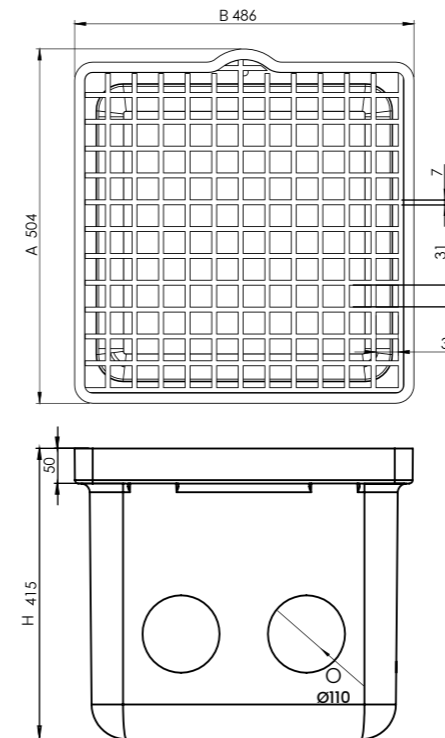

Type	Weight (kg)	Dimensions (mm)			
		A	B	H	O
B125	21	504	486	415	110

TIP 12, H41 Manhole Chambers '19x19 Grid'

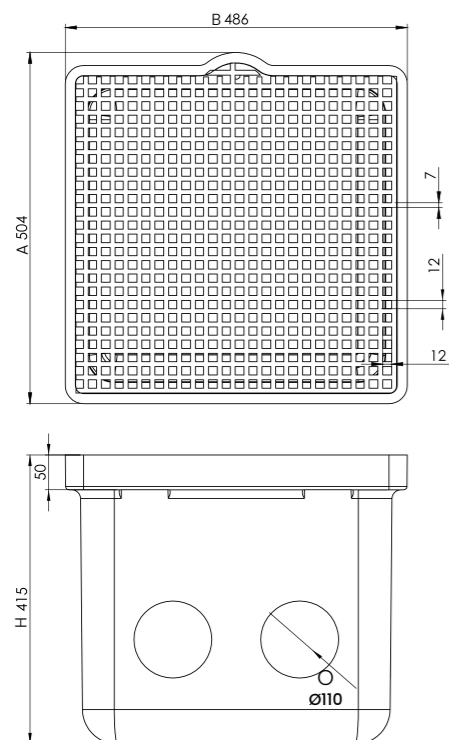

Type	Weight (kg)	Dimensions (mm)			
		A	B	H	O
B125	22	504	486	415	110



Drainage Channels

Drainage Channels

150 x 1000 x 110 Drainage Channel

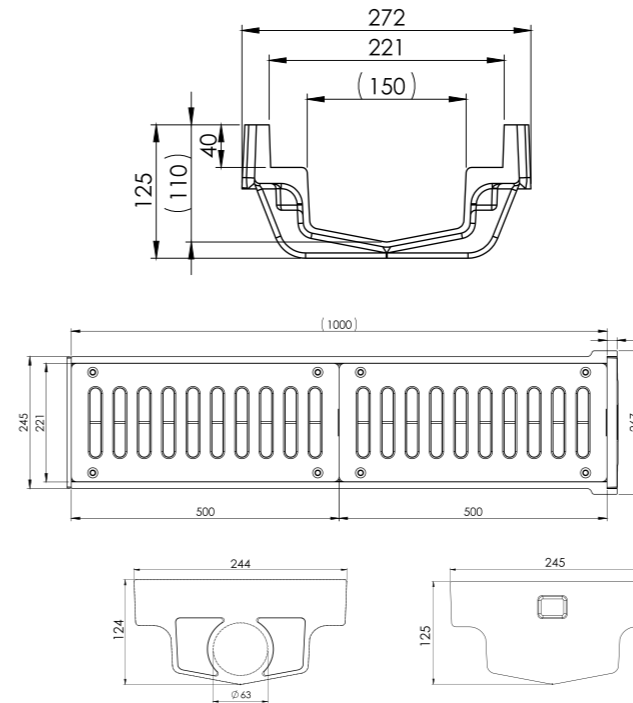

Product Code	Weight (kg)
B125	20,4
D400	24,6

150 x 1000 x 200 Drainage Channel

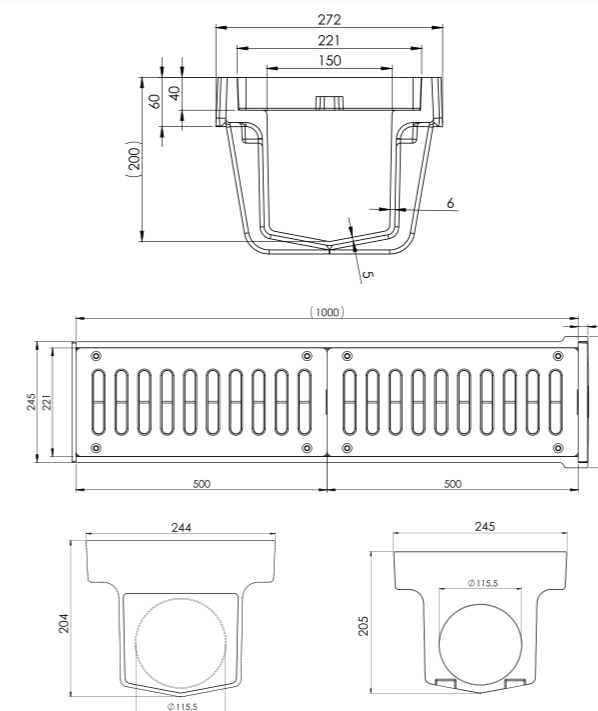

Product Code	Weight (kg)
B125	24,1
D400	28,3

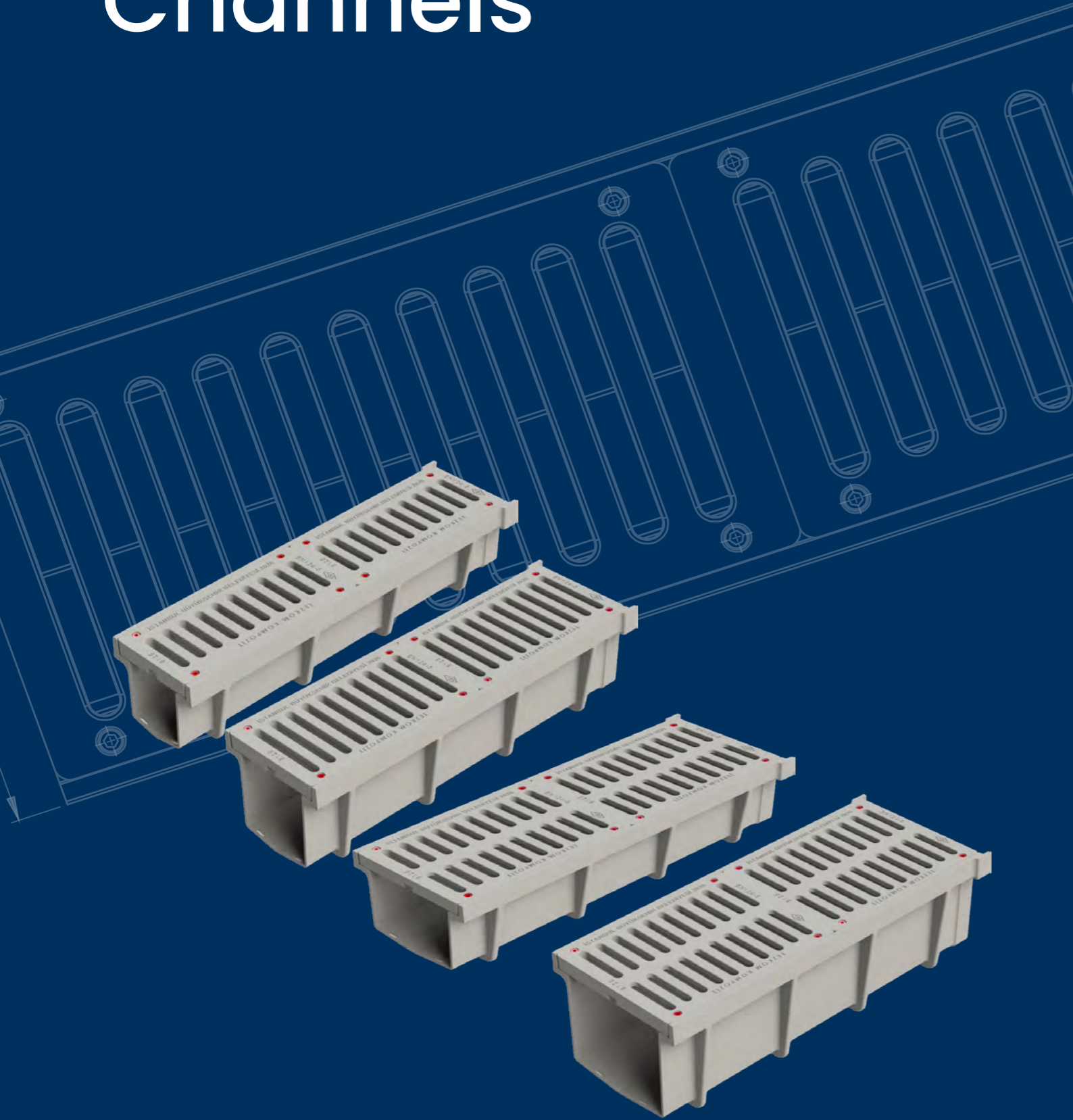

Drainage Channels

200 x 1000 x 110 Drainage Channel

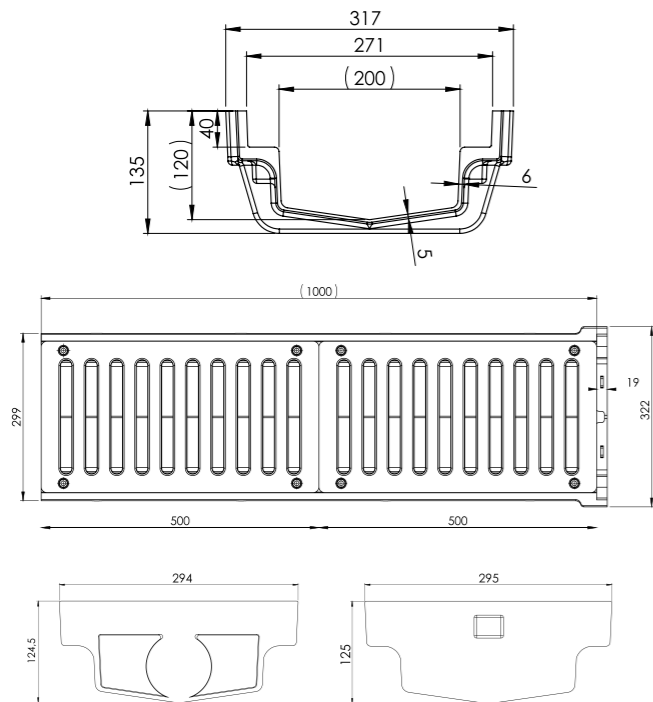

Product Code	Weight (kg)
B125	22,7
D400	30,3

200 x 1000 x 200 Drainage Channel

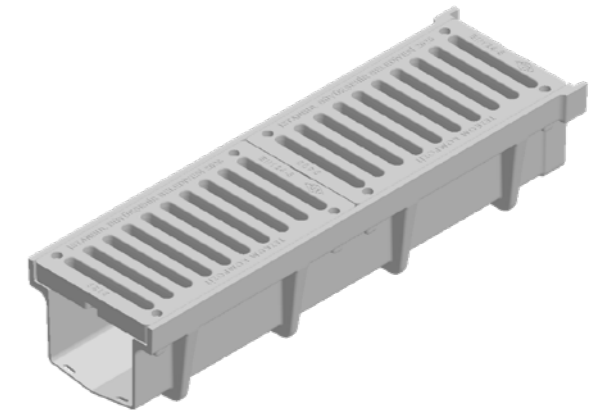
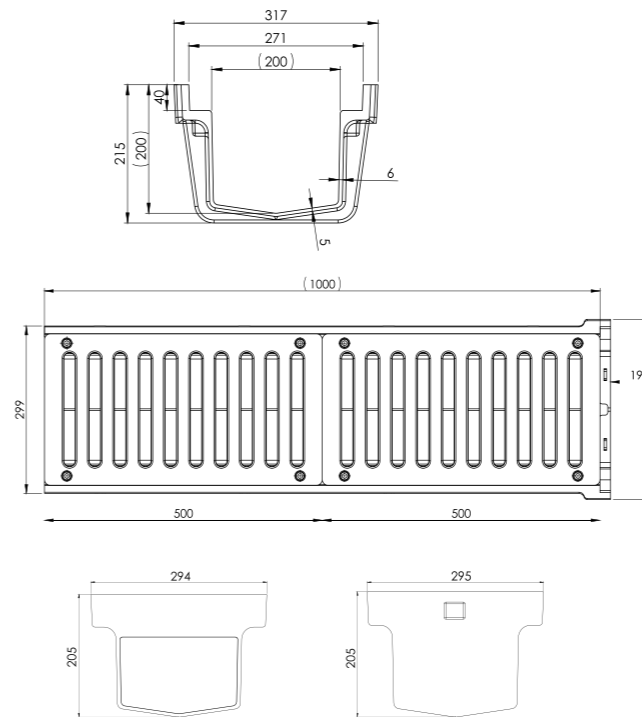

Product Code	Weight (kg)
B125	26,7
D400	34,3

200 x 1000 x 150 Drainage Channel

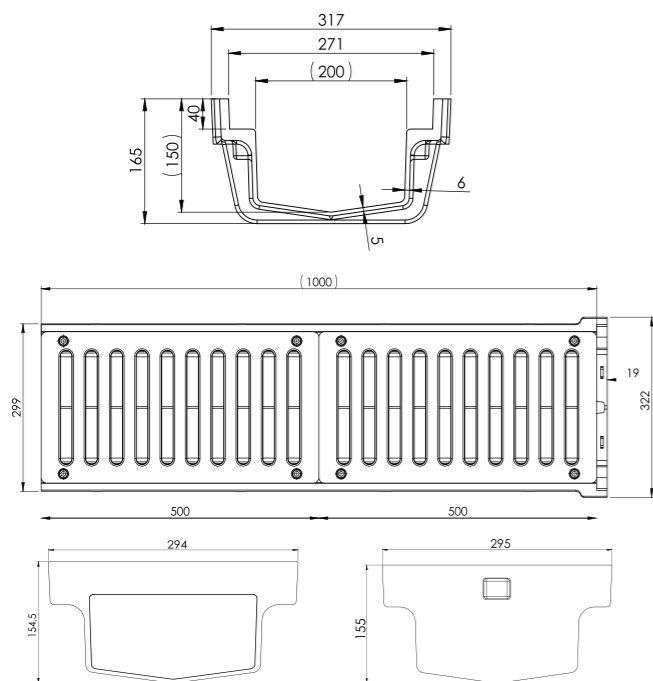

Product Code	Weight (kg)
B125	24,1
D400	31,7

200 x 1000 x 250 Drainage Channel

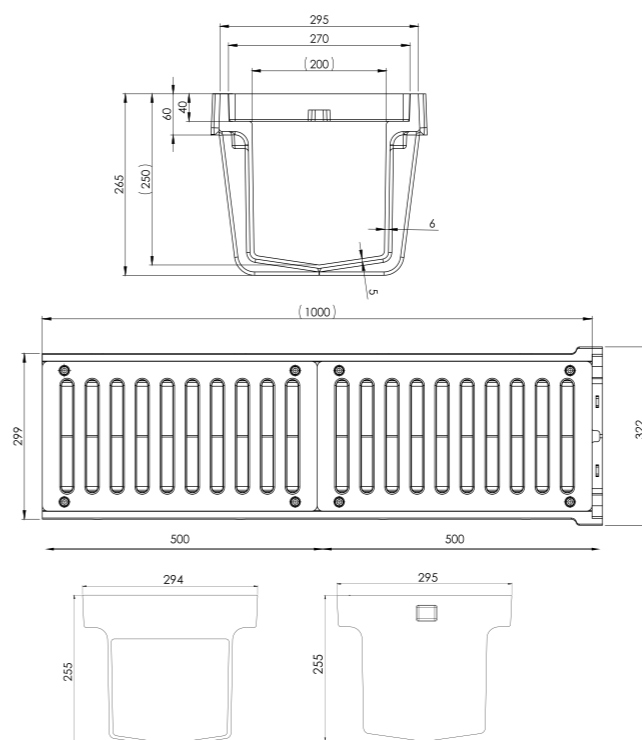

Product Code	Weight (kg)
B125	29,1
D400	36,7

Drainage Channels

250 x 1000 x 200 Drainage Channel

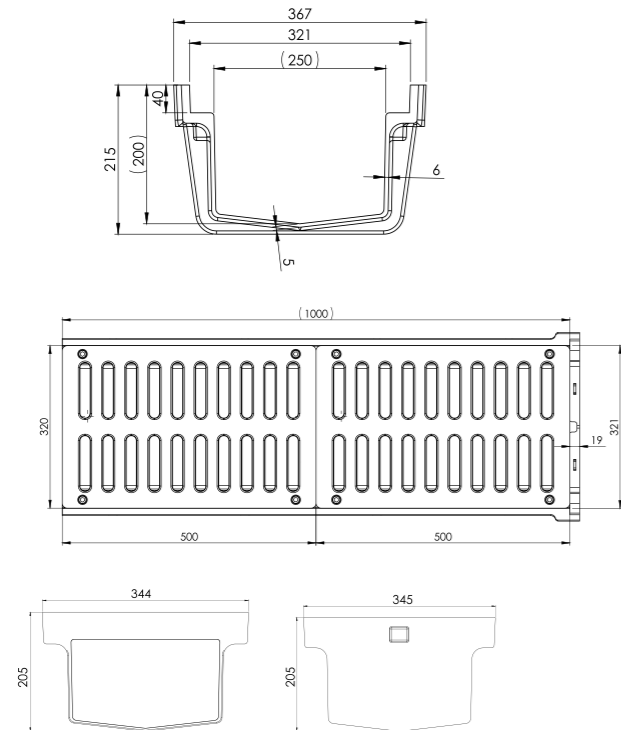

Product Code	Weight (kg)
B125	30,6
D400	46,4

300 x 1000 x 200 Drainage Channel

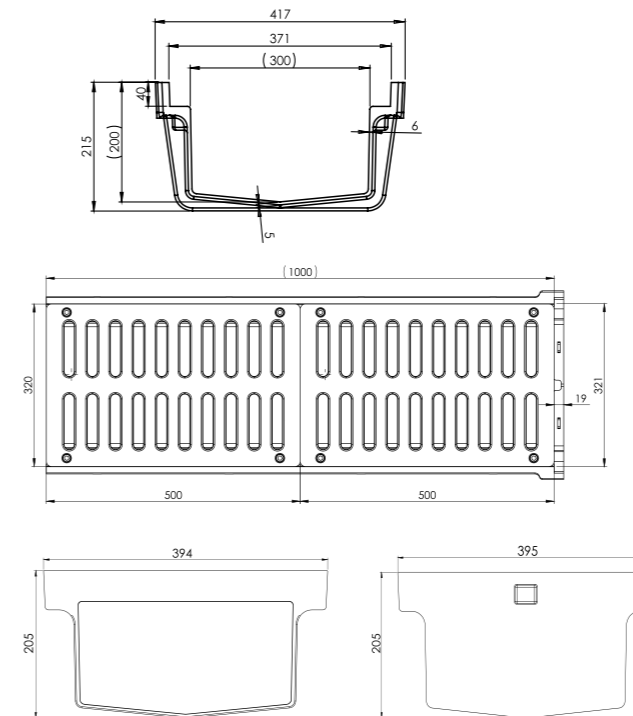

Product Code	Weight (kg)
B125	33,2
D400	47,4

250 x 1000 x 250 Drainage Channel

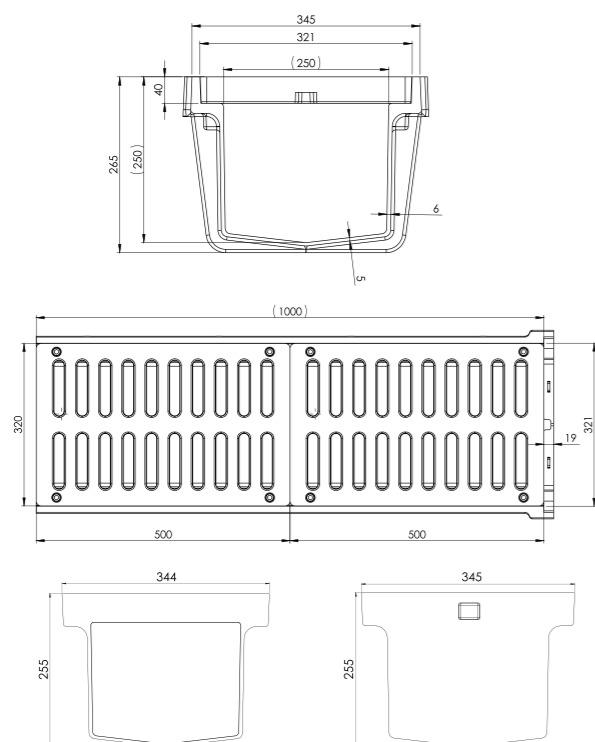

Product Code	Weight (kg)
B125	33,3
D400	49,1

300 x 1000 x 300 Drainage Channel

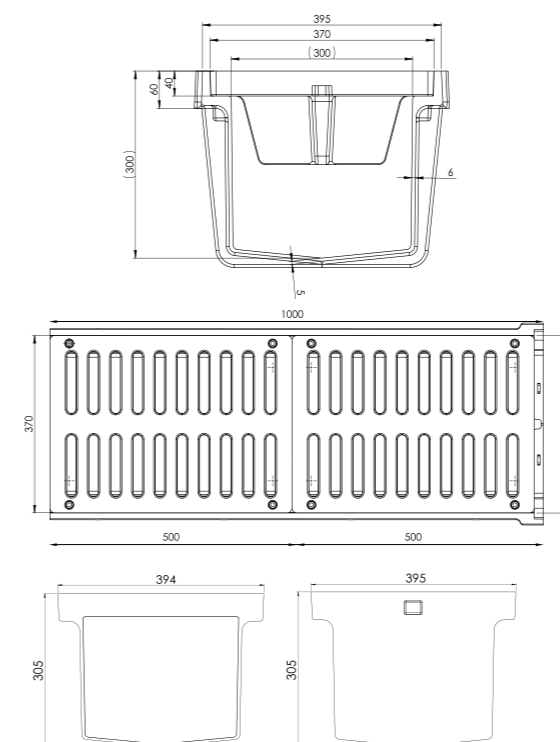

Product Code	Weight (kg)
B125	38,3
D400	52,5

Drainage Channels Grates

Drainage Channels Grates

400 x 600 x 60 Channel Grate

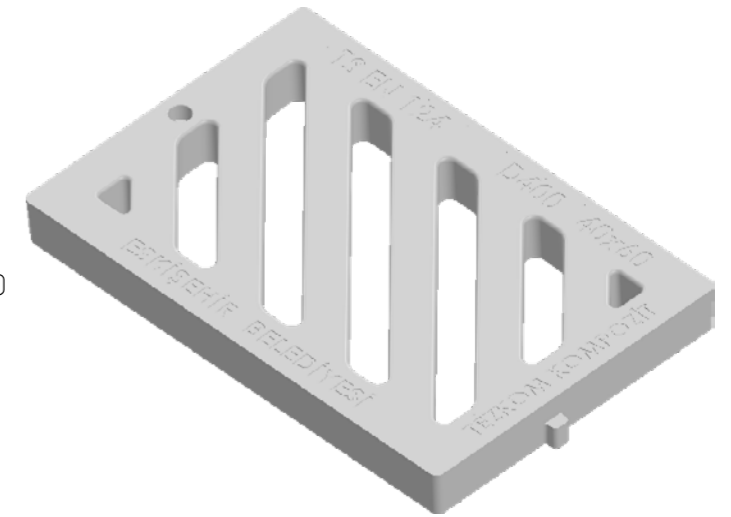
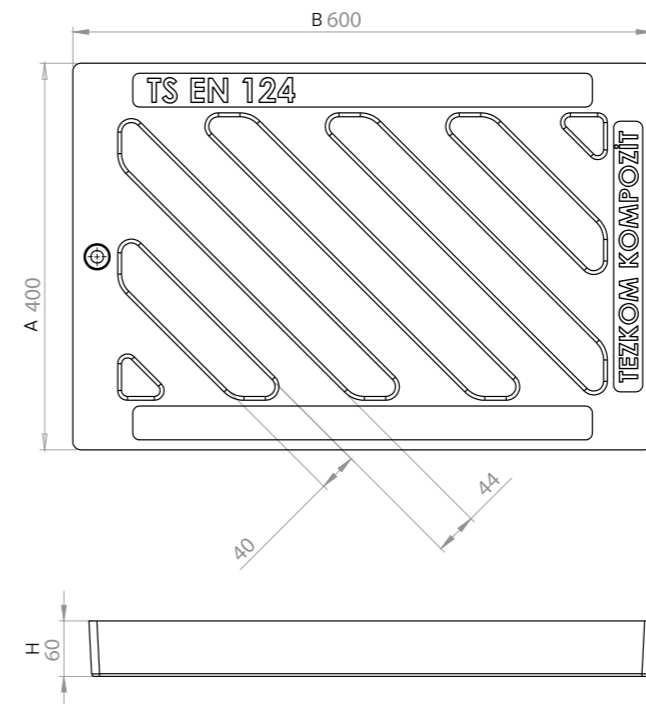

Product Code	Weight (kg)	Dimensions (mm)		
		A	B	H
D400	18,5	400	600	60

500 x 500 x 60 Channel Grate

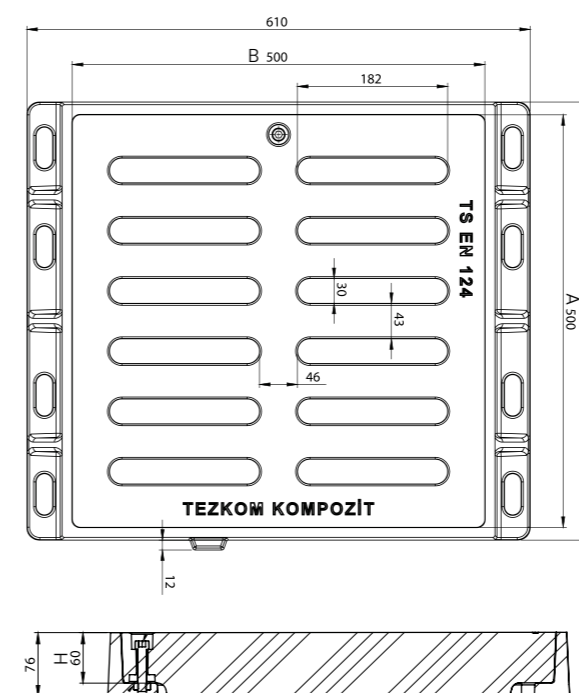

Product Code	Weight (kg)	Dimensions (mm)		
		A	B	H
D400	28	500	500	60

Drainage Channels Grates

570 x 570 x 60 Channel Grate

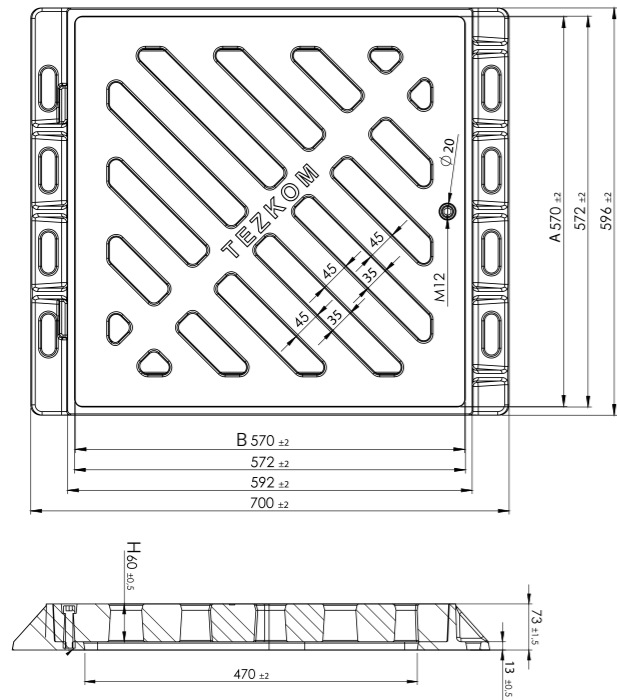

Product Code	Weight (kg)	Dimensions (mm)		
		A	B	H
D400	34	570	570	60

270 x 500 x 40 Channel Grate

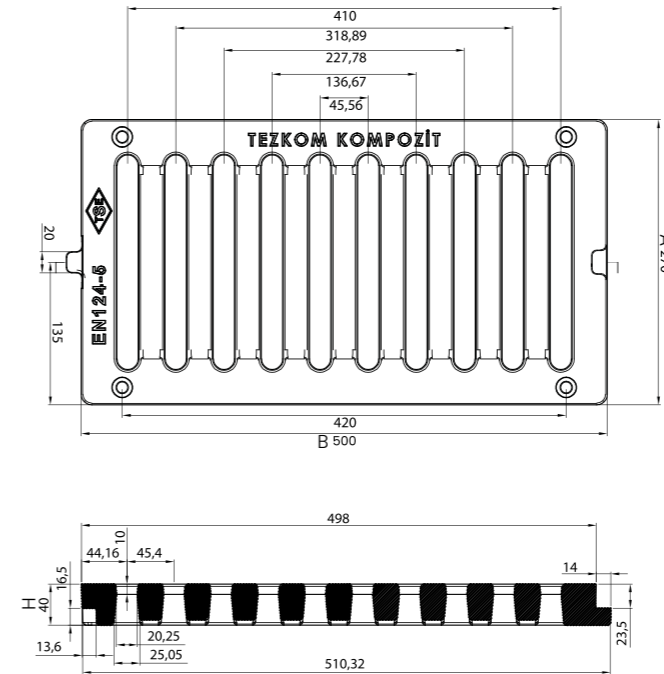

Product Code	Weight (kg)	Dimensions (mm)		
		A	B	C
B125	6,2	270	500	40
D400	10	270	500	40

220 x 500 x 40 Channel Grate

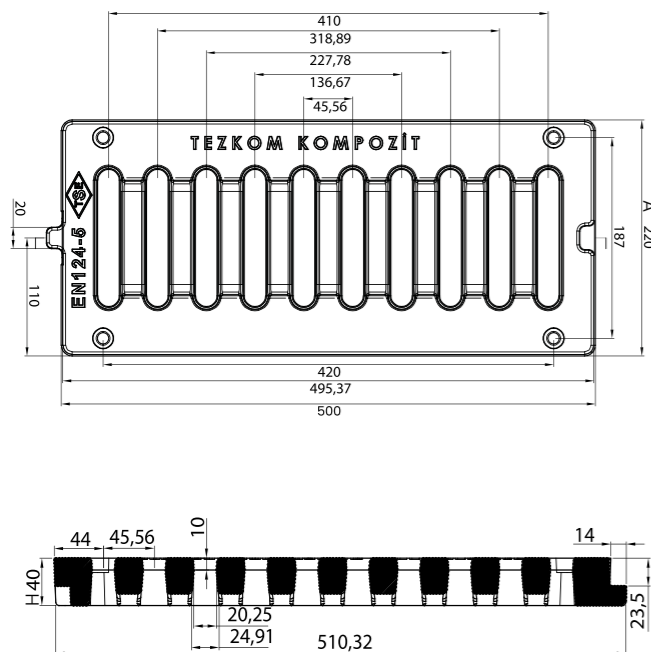

Product Code	Weight (kg)	Dimensions (mm)		
		A	B	H
B125	5,5	220	500	40
D400	7,6	220	500	40

320 x 500 x 40 Channel Grate

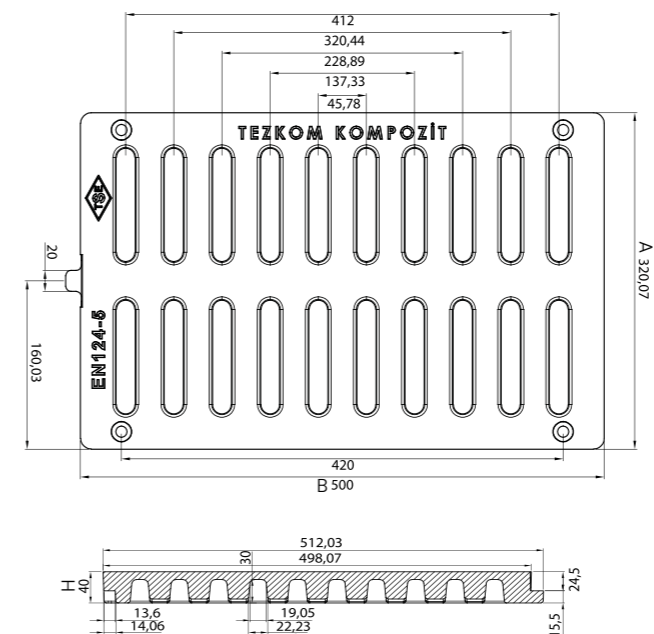

Product Code	Weight (kg)	Dimensions (mm)		
		A	B	C
B125	7,6	320	500	40
D400	15,5	320	500	40

Drainage Channels Grates

370 x 500 x 40 Channel Grate

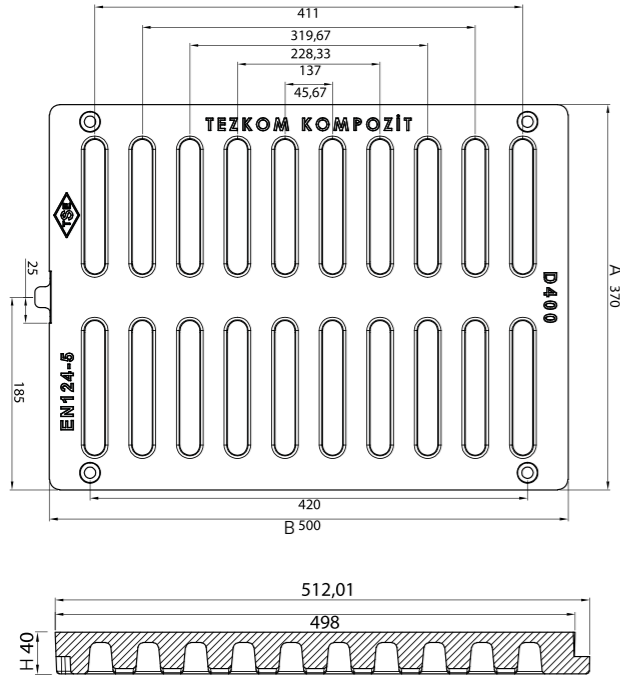

Product Code	Weight (kg)	Dimensions (mm)		
		A	B	C
B125	8,4	370	500	40
D400	15,5	370	500	40

